

## Class P, UL Listed Donut Shaped LED Driver for Universal Dimming Applications

### Features and Benefits

- Donut shape is ideal for pendant or round decorative fixtures with central shaft
- High efficiency constant current driver in compact white case reduces shadows in luminaire
- Class 2, UL 8750 listed Class P plastic case, IP62 rated
- Dimming < 5% (120VAC only) with triac/incandescent (forward phase) dimmers
- Dimming < 5% with 0-10V dimmers
- UNV input 120-277VAC
- Available in three outputs: 250mA, 350mA and 500mA



PS20-500C-DUALDIM-UNV-DONUT-P Series

### Compatible LED Modules

Nominal DC Output to Module ..... See Table 1

### Ratings and Performance Specifications

Nominal Power Consumption @ 120VAC .....	See Table 1
Nominal Input Voltage .....	See Table 1
Maximum Driver Case Temperature @ designated Tmp .....	+75°C
Maximum Operating Range Ambient Temperature (Ta) .....	-30 to +50°C
Recommended Screw Installation Torque .....	75 inch ounces
Nominal Power Factor .....	> 0.9
Nominal Weight .....	100 grams
Safety/Compliance .....	UL E256805
Designed to meet FCC Part 15B and Class A sound rating < 24dBA	
Designed to comply with IEEE C.62.41-1991, Class A operation	

### Application Notes

1. The proper driver case temperature at designated (T<sub>mp</sub>) is critical to ensure proper performance and long life. Careful design consideration required for factors such as ambient conditions (for example weather and surrounding atmosphere inside luminaire) and proximity to heat generating components.
2. Abnormal operating conditions such as elevated ambient temperatures can be expected to negatively impact output, product lifetime and/or product performance.
3. Dims only at 120VAC with most triac and 3-wire ELV dimmers such as Lutron® Diva and Maestro. Complete list of compatible dimmers and application notes available.

## Physical Dimensions

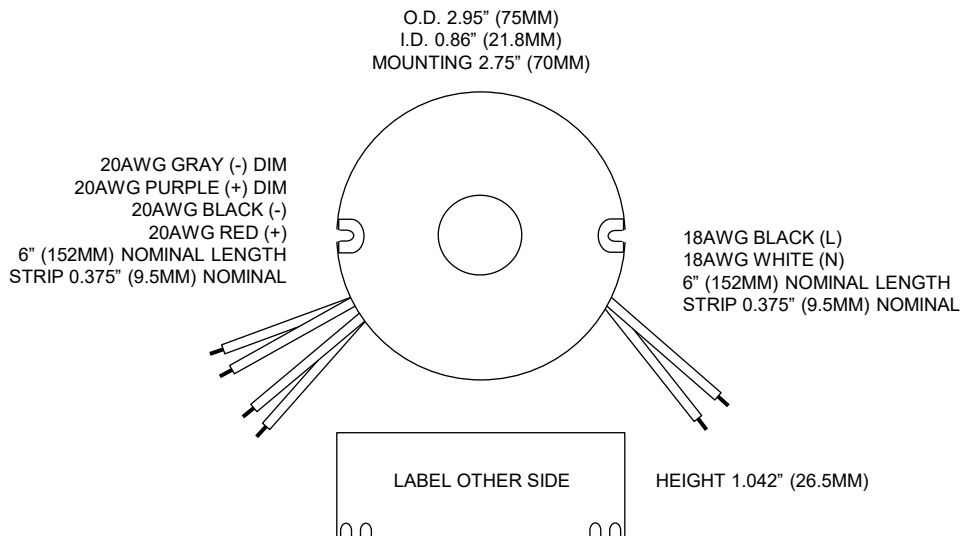

**Table 1, Performance Characteristics at 25°C**

Part Number	Max Output Power (DCW)	Nominal Input Voltage (VAC)	Triac Dim (VAC)	0-10V Dim (VAC)	Nominal Output Current (mA DC)	Output Voltage Range (VDC)	Efficiency @120VAC Max Load
PS20-500C-DUALDIM-UNV-DONUT-P	20	120-277	120VAC	120-277VAC	500	20 - 40	84%
PS20-500C-DUALDIM-UNV-DONUT-P-350MA	14	120-277	120VAC	120-277VAC	350	20 - 40	84%
PS20-500C-DUALDIM-UNV-DONUT-P-250MA	10	120-277	120VAC	120-277VAC	250	20 - 40	84%

Contact Forlux for complete list of compatible dimmers and application notes

## Packaging

Product is marked with SKU and lot information.

Sold in groups of (1) unit(s) and packaged with SKU and lot information.

## Warranty

5-Year limited warranty in accordance with published warranty conditions. Product must be used with compatible components (modules, drivers, engines and/or accessories) and no maximum ratings (such as Ts) shall be exceeded during any operating conditions of the system. If product is used with other manufacturer's product, compatibility must be recognized in writing by Forlux.

Forlux owns the following United States patents of which may be applicable to the design or manufacture of this product: 6712486, 6578986, 6846093, 7114831, 7306353, 7102172, 7108396, 7329024, 7387406, 7582911, 7649327, 8926145, 8729810. Additional granted patents, patents pending and other IP protection rights may apply.